

Specifications of Single Container Water Hammer Tester

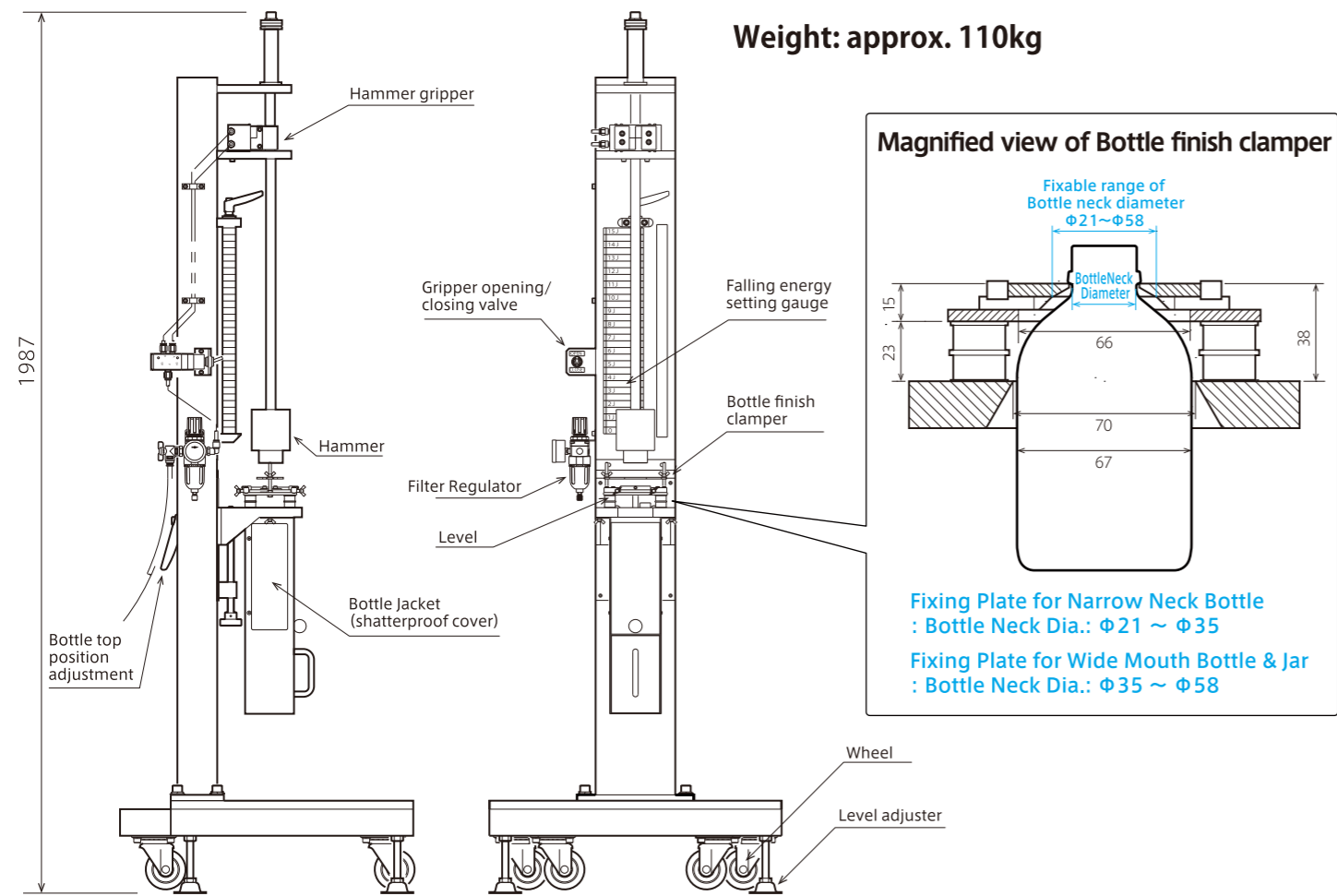

Innovative testing device for water hammer strength of glass containers

Single Container Water Hammer Tester

JP PAT.No 4598153
US PAT.No 9021858
CN PAT.No ZL2010 8006 3508.6

Specifications

1. Testable Glass Bottle

**Will be discussed, if you would like to test any out-of-specification bottle.

- Neck Diameter : Min. $\Phi 21 \sim$ Max. $\Phi 58$
- Weight : Max. 1300g (total weight of a closure + liquid content + a glass bottle)
- Bottle Height : Max. 280mm (without a bottle jacket: Max. 400mm)
- Body Diameter : Max. $\Phi 85$ mm (without a bottle jacket: Max. $\Phi 105$ mm)
- Bottle Shape : refer to the above "Magnified view of Bottle finish clamber"

2. Supply Energy

- Compressed Air (0.2 ~ 0.3Mpa)

3. Warranty

Toyo Glass warrants the tester itself against defect and breakdown when used normally in accordance with Toyo Glass's published instruction manual for a period of ONE (1) year from shipment. This warranty does neither apply to any damage caused by the tester's breakdown. Components which wear are not warranted.

Precautions

1. Testable liquid content with this tester is (1) foods and (2) non-carbonated beverages.
2. For safety purposes, an operator shall always wear safety protective equipment (full-face mask and gloves) when he uses the tester. And, he shall confirm there is none who doesn't wear the above protectors around the tester.
3. The stopper for anti-drop of the hammer should be used at the time of setup of the tester and replacement of the bottle fixing jig.

 **TOYO GLASS MACHINERY CO., LTD.**

<http://www.tgmm.co.jp/>

Machinery Sales Section, Sales Department, Sales Division

E-mail: info@tgmm.co.jp URL: <http://www.tgmm.co.jp/>
TEL: +81-45-585-1911, FAX: +81-45-570-4515
Address: 1-1-70 Yako, Tsurumi-ku, Yokohama 230-0001 JAPAN

 **TOYO GLASS MACHINERY CO., LTD.**



Single Container Water Hammer Tester

Innovative water hammer strength tester with highly-improved work efficiency.

It enables quick feedback for better product strength design.

The conventional water hammer strength test has been conducted in the same condition as actual transport of glass containers.

Consequently, in this method, we have to wait until glass bottles are filled and packed in cartons at a customer. Therefore, in the case of poor water hammer strength, it takes a lot of time and effort to confirm the efficacy of countermeasures for better bottle strength.

In order to reduce such undesired time and effort, Toyo Glass has developed "Single Container Water Hammer Tester" which enables to immediately evaluate water hammer strength of a glass bottle right after the bottle is produced.

The most distinctive feature of this testing device is that only a single glass bottle is loaded on the device for a test. This device realized a simple test process in which a glass bottle is vertically dangled on the device at its neck and a weight is dropped on the top of the bottle from above to generate a water hammer phenomenon.

The user can immediately evaluate a bottle strength right after the bottle is produced and see its strength by mold number to check if there are any differences or tendencies among mold numbers. In addition, as no carton is required, the strength of a glass bottle itself can be examined, and consequently it is possible to recognize a detailed relation between the water hammer strength and the shape or the thickness distribution of a glass bottle. Furthermore, it shortens time and simplifies work for a water hammer strength test.

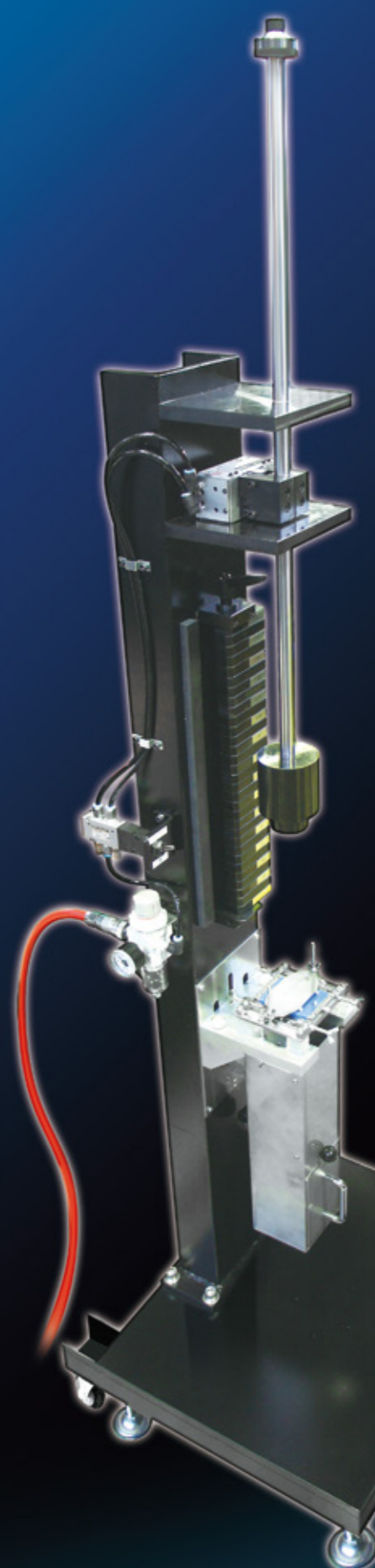

With a single glass bottle without a carton

As no carton is required, only the strength of a glass bottle itself can be examined

Single Container Water Hammer Tester measures water hammer strength of a glass bottle by dangling a bottle at its neck and then dropping a weight on the top of the filled and capped bottle from above to generate a water hammer phenomenon. In order to recognize the water hammer strength, the position of a weight is lifted in a step-by-step manner up to the point where the glass bottle breaks. In the conventional test with a carton containing many glass bottles, a test result can be affected by the material, dimensions and strength of the carton. On the other hand, this device can measure only the strength of a glass bottle itself.

Strength can be examined by mold number to check if there are any differences or tendencies among mold numbers

Comparative water hammer strengths can be recognized between similar glass bottles

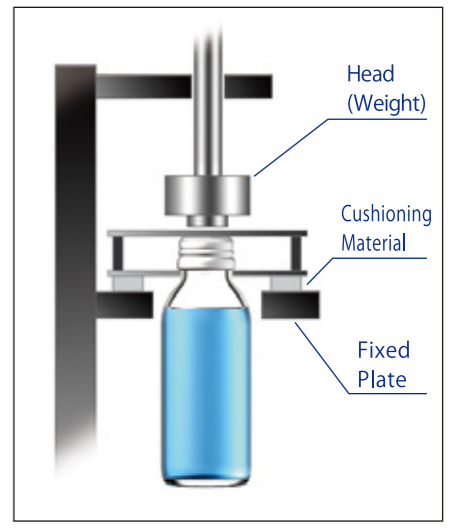

Conceptual Diagram of Testing Device

Simple work and short test time

Work efficiency can be improved by eliminating inefficient work of the conventional test

In the conventional test method, about 100 to 200 bottles and cartons actually used for transport were needed to conduct a test. Meanwhile, this device dramatically improves the work efficiency of a test compared with the conventional test with cartons because it requires less sample glass bottles (about 20 bottles, 1 bottle per mold number) and eliminates such work as lifting a carton, checking a crushed carton and verifying a broken bottle.

A test can be conducted immediately after a bottle is produced

As this test can be done only with a single glass bottle, the user can promptly feedback the result of strength test and smoothly proceed product designs.

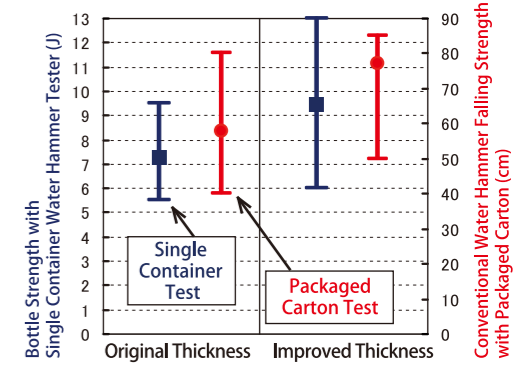

A similar tendency of water hammer strength is seen between the test results with a single glass container and with a packaged carton.

Reproducible water hammer phenomena through bottle neck holding

No undesired reaction force occurs by hanging a glass bottle in the air

Glass bottle falls exactly vertically

When a glass bottle fails to drop vertically, wrong stress values can be generated on the bottom of the bottle. In order to minimize variability of stress on the bottle bottom, the special supporting guides which assist the bottle to vertically drop are set up on this device. These supporting guides ensure precise replication of water hammer phenomena and its superior basic performance as a testing device.

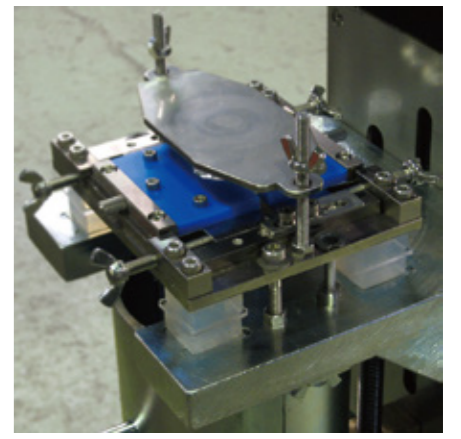

Supporting guides are set up to assist the glass container to fall vertically.

What is a water hammer phenomenon?

During transportation of filled glass bottles, cartons positioned at the bottom may be crushed by downward impact. In such a case, glass bottles in the carton just above those bottom cartons suddenly drop, and some of them may break. This is usually called a "water hammer phenomenon".

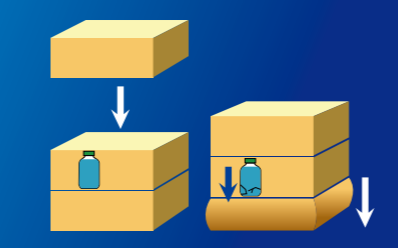

Process of glass bottle breakage caused by a water hammer phenomenon

- ① A filled glass bottle rapidly falls down.
- ②-1 The liquid content remains in the same position inside the bottle by its inertia force.
- ②-2 The volume of the head space above the filling point is reduced.
- ②-3 To compensate the reduced volume of the head space, cavities are generated between the liquid content and the bottle bottom.
- ③ When a cavity collapses, it engulfs its surrounding water and a microjet arises, and then tiny cracks (impact traces) are formed on the heel and bottom of a glass bottle.
- ④ The liquid content falls down due to the high pressure in the head space and gives a strong impact on the bottle bottom.
- ⑤ Stress is concentrated on the inside surface of the bottle heel and the glass bottle starts to break from the tiny cracks on the bottle heel.

